



# Access Easy Controller 2.1



- ▶ 4 access Wiegand readers expandable to 16
- ▶ Capacity up to 20,480 card holders and 100,000 transactions
- ▶ Classify cardholders based on 254 access groups
- ▶ 255 time schedules, 32 regular and 32 special holidays
- ▶ Anti-passback (APB) capabilities
- ▶ 8 Alarm Zones and attendance capture
- ▶ Intrusion monitoring up to 32 input and control points
- ▶ E-mail or SMS Alert for critical events
- ▶ Integration with video devices for video verification and video event search
- ▶ Multiple language selection

Access Easy Controller 2.1, (AEC2.1) is a new generation IP web based access controller that uniquely combines the features of a web server, video integration and security system in one complete unit. The new user interface allows more intuitive operation and improved reports capability to give the operator more control and efficiency.

Any computer platform capable of running a standard web browser can be used to access, monitor, manage, and control an AEC2.1, which in turn controls doors, access readers, alarms, cameras and other devices.

## Functions

### Web control Interface

AEC2.1 has a built-in web server that allows monitoring and programming of control parameters using any standard Web browser.

### Network Ready

AEC2.1 is a network-ready system that connects easily to any TCP/IP network via an Ethernet port. Any client computer in the network can access the AEC to manage the database, monitor activity or control devices.

### Administration and User

- 25 maximum user accounts
- 128-bit SSL browser Login encryption
- Case sensitive user IDs and passwords

### Log-on Access Rights

All user IDs and passwords are encryption protected, allowing only authorized persons to access the AEC to monitor and manage the system parameters, transaction records, and activities.

### Multiple Entry Access Mode

Three different access modes are available to cater to your own unique security requirements:

- Card only
- PIN only
- Card & PIN

### User-Definable Personal Identification Number (PIN)

Each cardholder is given the flexibility to choose his or her own 4 to 7 digit personal identification number.

### Multi-Functional Card Assignment

The ability of a single card to perform multiple functions: A card can be programmed to function as

- Normal access card
- Attendance card
- Arming/disarming card

## Time Schedules

Up to 255 sets of programmable schedule types can be defined to provide access control functionality such as door locking or unlocking, PIN function activation or automatic arming/disarming of an alarm point, sending an Email/SMS, automatic on/off of lights, aircon etc.. Within each schedule type, four programmable time intervals can be set for each day of the week, special and regular holidays.

## Storage and backup

All transaction records, cardholder's data and system control parameters are stored in the compact flash memory. All data will remain intact on the compact flash even if the system experiences a power failure.

## Video Integration & Monitoring

AEC2.1 provides seamless integration with IP cameras, digital and network video recorders. The video integration allows the system to link certain events to cameras, to view live or playback video. Up to 3 live video cameras can be configured to each reader, input/output point and advance IO function block. The Live video of the surveillance window will pop up automatically when an alarm event is triggered in the configured location. The event video clip can be downloaded to the PC for later investigation. The video verification function enables automatic live video display of the access point for comparison with cardholder's photo.

**Note:** The video recording is taken care of by the video device and not the AEC system.

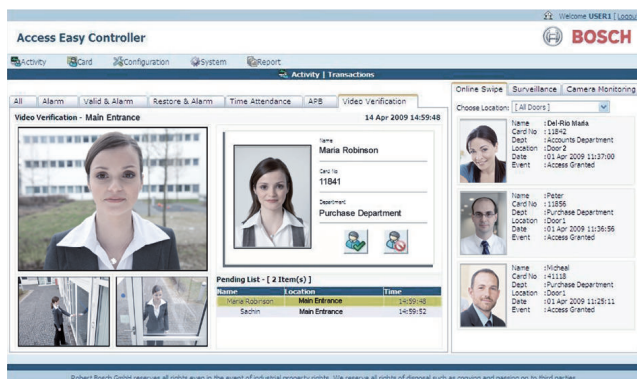

## Intrusion Alarm Monitoring

Provides 2 or 4-state alarm monitoring on all inputs. An access reader can be programmed as an alarm arming/disarming reader.

## Alarm Input and Relay Outputs Control

Up to 32 inputs and 32 relay outputs can be software-configured for door strike controls, sirens, alarm shunting, vehicle boom barrier controls and a host of other applications.

(32 inputs / outputs are available via the AEC extension.)

## Advance IO Programming

Unique programming options for input and output linking based on logic programming. Predefined applications such as Guard Tour, Feed Through, OR logic, AND logic, XOR logic, NAND logic, Interlock, Up-Down Counter, Exit Door, One Shot and Intrusion are available. Types of input and output linking are not restricted just to IO devices: inputs can be any one of 'inputs', 'outputs', 'inter-connection (logic) links', 'schedules', 'criteria', 'always on' or 'always off'. Outputs can be any one of 'inter-connection (logic) links', 'outputs', or 'access readers'. With this sophisticated logical IO programming, the system is ready to handle automation in virtually any situation.

## Anti-passback Capabilities (APB)

Anti-passback is a sophisticated security feature in access control to prevent fraudulent multiple-entry (e.g. a cardholder passing his/her card to another person) by blocking repeat entry at the same door within a set time-period. Three types of APB are available, providing variable levels of security: Time based APB, Soft APB, and Full APB. Time based APB prevents the same card from re-entering by the same door within a set time period (maximum 60 minutes). Full APB follows strict rules: it controls access by monitoring the sequence of entries at defined APB entry readers, and exits at defined APB exit readers. Any violation of the sequencing will prevent access. Soft APB is similar to full APB except that it will allow exit via exit readers even if a corresponding entry has not been recorded. Transaction records in Soft APB will differ from normal transactions. 254 levels of APB are available to group related sets of APB entry and exit readers. Using APB configuration the system can provide the master list of the cardholders violating the APB settings in a zone or area.

## Remote System Administration

This enables the user to dial into the AEC2.1 via telephone modem to perform remote administration. Once connected, access and control of the AEC2.1 can be carried out via the web browser.

## Internet E-mail (SMTP) & Short Message Service (SMS) Support

AEC2.1 can send e-mail, based on triggered events or transactions under normal or alarm conditions. Each mail message consists of a full description of the event or alarm, its location, ID and a date/ time stamp. E-mail can be sent to multiple recipients or relayed as an SMS text message to mobile phone users via certified modems. This function provides unlimited, secure, fully-configurable information transfer to operators.

**Note:** Requires GSM modem for SMS

## Easy Firmware Upgrade

AEC2.1 utilizes state-of-the-art flash memory technology to store its firmware. Upgrades can be carried out by replacing the physical flash module or by firmware update.

## Certifications and Approvals

The AEC2.1 is designed to comply with the following certifications, approvals, and safety standards:

- CE
- FCC
- UL (in progress)

## Installation/Configuration Notes

### Ethernet Installation

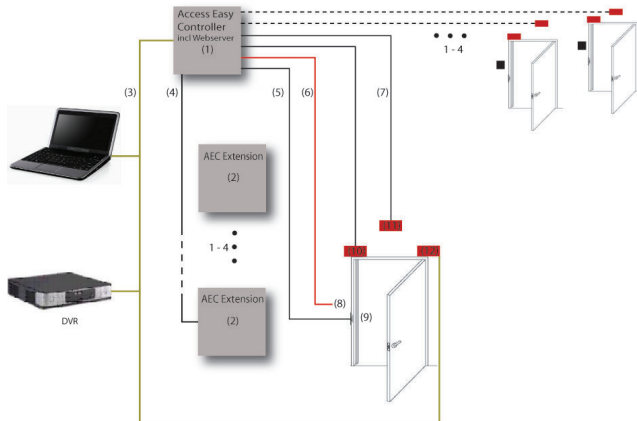

- (1) AEC Main Controller incl. Webserver
- (2) AEC Extension
- (3) 100BaseT Ethernet, max 100 m\*
- (4) 22 AWG, 2-conductor, shielded, 1000 m\*
- (5) 18 AWG, 2-conductor, unshielded, 200 m\*
- (6) 22 AWG, 6-conductor, shielded, 100 m\*
- (7) 22 AWG, 2-conductor, unshielded, 305 m\*
- (8) Reader
- (9) Door strike
- (10) Door contact
- (11) Exit device
- (12) Video Device

\*) cable types are only examples

### System Parameters

- 4 access readers expandable to 16 access readers
- 254 access groups
- 255 time schedules
- 32 regular holidays & 32 special holidays
- Anti-passback (APB) capabilities (Full, Soft, Time Based)
- 100,000 transactions history
- Audit log
- Real-time activities and status update
- Built-in reporting functions (transactions & system logs)

### Card Access Parameters

- 20,480 card capacity
- 16 programmable Wiegand card formats
- Multi-card function type: normal, attendance capture, arm/disarm

- Multi-operation method by
  - card only
  - card + user PIN code, 1-7 digits
  - reader's PIN code, 1- 7 digits
- Batch entry - card add/delete feature
- Card details - Card number, Facility code, Card format, User name, Department, 2 user definable fields, 2 definable access groups
- Programmable card validation period - supports one-time access
- Supports Dual Card Entry (2 man rule)
- Supports card database Import and Export in CSV Format

### Access Readers and Door Parameters

- Definable entry or exit reader, arm/disarm reader, or elevator reader
- Enable or disable keypad on the reader
- Keypad time-out, 0-255 sec
- Operation using reader's PIN only, 1-7 digits
- Lockout reader based on illegal attempts, 0-255
- Lockout duration, 0-255 sec
- Illegal event types include: Access Denied, Access Denied - APB, Access Denied - Timed APB, Access Denied - Wrong PIN, Invalid Schedule, Invalid Card, Invalid Start Date, Invalid End Date, Invalid First Card, Invalid Second Card, and Duplicate First Card.
- Auto lock/unlock (schedule controlled)
- Lock/unlock of doors via access reader
- Lock/unlock/momentarily unlock of doors
- Door open timer, 0-255 sec
- Door strike timer, 0-255 sec
- Alarm delay duration for door forced open, 0-255 sec
- Pre-alarm warning before door held open, 0-10 sec

### Video Parameters

- Supports max. 3 cameras for each reader
- 64 cameras
- View live and playback video
- Enables automatic live video display of the access point for comparison with cardholders photo
- AEC2.1 integrates with the following video devices
  - IP Cameras: AutoDome IP, Dinion IP, FlexiDome IP
  - Encoders: VideoJet X10 , VIP10, VIP-X
  - DVR/NVR: DiBos, DivarXF, Vidos NVR4.0

**Note:** Video integration features are available on Windows OS only.

### Alarm and IO Status Parameters

- Max. 32 input monitoring points
- Max. 32 outputs
- Automatic incoming power failure monitoring
- Real-time alarm transaction monitoring
- Instant & delay alarm monitoring for any input
- Programmable alarm point description
- All input monitoring supports 2 state non-supervised, 2 state supervised, and 4 state supervised
- Programmable arm/disarm of alarm zones
- Programmable arm/disarm status LEDs
- Programmable output control
- Programmable input-output linking
- Door held open/forced open alarm reporting
- Duress alarm (from PIN readers)
- Tamper alarm (enclosure opening)
- Common Alarm Output

- Advanced programmable IO features (guard tour, feed through, OR logic, AND logic, XOR logic, NAND logic, Interlock, up/down counter, exit door, one shot and intrusion)

#### E-mail/SMS Parameters

- SMTP- based Email
  - E-mail upon triggered events (based on selectable events, devices and/or cardholders)
  - Attendance capture transactions and lateness reporting
  - Hardware failures auto reporting
  - 8 programmable groups e-mail recipients with attached messages
  - 8 programmable messages.
- Note:** Requires GSM modem for SMS

#### Database Maintenance

- Automatic daily backup to compact flash memory
- Manual backup of systems database and/or Activity, audit log, and Attendance Capture Record to local client PC.

### Technical Specifications

#### Dimensions

Enclosure (H x W x D)	400 x 400 x 94 mm (15,75 x 15,75 x 3,7 inch)
-----------------------	---

#### Environmental conditions

Relative Humidity	10% to 90% at 32 °C (+90 °F)
Temperature (Operating)	0 °C to +50 °C (32 °F to 120 °F)
Temperature (Storage)	0 °C to +55 °C (32 °F to 130 °F)

#### Ports

LAN Ports	Two RJ45 Ethernet
Serial Ports	Two RS-232
Extension port	One RS-485

#### Interface 4-Reader Board

Voltage Requirement	12 VDC from PSU
Number of Wiegand Readers supported	4
Number of Monitoring Points	8*
Number of Output Control Relays	8**

\*) Input Monitoring Points on the 4-Reader board consists of door contact input and request-to-exit inputs associated with reader controlled door.

\*\*) Output Control Relays on the 4-Reader board are the door strike/magnetic lock control relays for the reader-controlled doors.

#### Interface 8-Input/Output Board

Voltage Requirement	12 VDC from PSU
Number of Wiegand Readers supported	-
Number of Monitoring Points	8
Number of Output Control Relays	8

#### Readers Supported by AEC2.1

Standard Wiegand Input Reader	HID MiniProx Reader
	HID ProxPoint Reader
	HID ProxPro with/without Keypad Reader
	HID ICLASS with/without Keypad Reader (R10, R30, R40)

#### AEC2.1 Capacity

CPU	32 bit microprocessor – 500 MHz or higher
Memory	512 MB RAM or higher
Storage	CompactFlash 512 MB or higher
Concurrent Users	7 concurrently + 1 super-user
User licenses	Max. 25 user account, using (up to) 50 character alphanumeric, case sensitive user IDs and passwords
Events	100,000 transaction history, stamped with date and time
Database Integrity	Encryption used for user IDs and PINs
Number of Cards Supported	20,480
Number of Access Groups	255
Number of Time Schedules	255
Interval per Time Schedules	Four interval per day, plus holidays support
Recommended Web Browser	Microsoft Internet Explorer version 7.0 and above

#### Supported 4-Reader Board in a Full AEC2.1 Configuration

Max. Number of Interface board	4
Max. Number of Wiegand Reader	16
Max. Input	32 (Reserved for Door contact and request to exit)
Max. Output	32 (Reserved for Door strike)

#### Supported 8-Input/Output Board in a Full AEC2.1 Configuration

Max. Number of Interface board	4
Max. Number of Wiegand Reader	-
Max. Input	32 (Both normally opened and normally closed devices supported)
Max. Output	32 (Form-C PCB mounted output control relays, with Contact Rating: 1A@ 24 VCD)

**Power Requirements**

Primary Voltage Input (AC)	100 ~240 VAC
Secondary Voltage Input	+5 VDC for CPU board + 12 VDC for 4-Reader an 8-I/O-boards
Backup Battery (Optional Backup Battery: Not included in standard package)	12 VDC, 7AH rechargeable battery

**Ordering Information**

<b>AEC2.1 Main Enclosure, PSU1</b> Access Easy Controller 2.1 Enclosure with CPU Board, 4 Wiegand Reader Board, 100-240VAC Power Supply Unit, Compact Flash with software application, Quick Start Guide and CD-ROM containing software tools and manuals.	<b>APC-AEC21-UPS1</b>
<b>AEC2.1 Extension Enclosure, PSU1</b> Access Easy Controller 2.1 Extension Enclosure with 100-240VAC Power Supply Unit	<b>AEC-AEC21-EXT1</b>
<b>AEC2.1 4 Wiegand Reader Board</b> Access Easy Controller 2.1 4 Wiegand Reader with 8 Input-Output Board	<b>API-AEC21-4WR</b>
<b>AEC2.1 8 Input-Output Board</b> Access Easy Controller 2.1 8 Input-Output Board	<b>API-AEC21-8I8O</b>

**Americas:**  
Bosch Security Systems, Inc.  
130 Perinton Parkway  
Fairport, New York, 14450, USA  
Phone: +1 800 289 0096  
Fax: +1 585 223 9180  
security.sales@us.bosch.com  
www.boschsecurity.us

**Europe, Middle East, Africa:**  
Bosch Security Systems B.V.  
P.O. Box 80002  
5600 JB Eindhoven, The Netherlands  
Phone: + 31 40 2577 284  
Fax: +31 40 2577 330  
emea.securitysystems@bosch.com  
www.boschsecurity.com

**Asia-Pacific:**  
Robert Bosch (SEA) Pte Ltd, Security Systems  
38C Jalan Pemimpin  
Singapore 577180  
Phone: +65 6319 3453  
Fax: +65 6319 3499  
apr.securitysystems@bosch.com  
www.boschsecurity.com

**Represented by**