

# Keyscan CA4500

4-reader access control unit

With an emphasis on innovation and sustainability, you can trust the Keyscan CA4500 access control unit for smart access control technology and system design flexibility. Keyscan CA series of door controllers are compatible and merge security with convenience. The CA series can satisfy any new installation requirement or augment existing Keyscan systems while, in many cases, utilizing existing infrastructure including credentials.

**CA4500 includes:**

- CA4500B ACU board
- 1-OCB8 relay board
- 1-DPS-15 power supply
- 1-black metal enclosure with lock and tamper switch

**Keyscan CA4500 features:**

- Network TCP/IP ready
- Easily configurable reader settings supporting many Wiegand protocols
- Auto-transfer protocol uploads transaction buffer if interruption occurs
- Dual processors
- Lock down and global communication among multiple ACUs, server and sites (requires CIMs and CIM Link)
- Multiple inputs and outputs for expansion capability

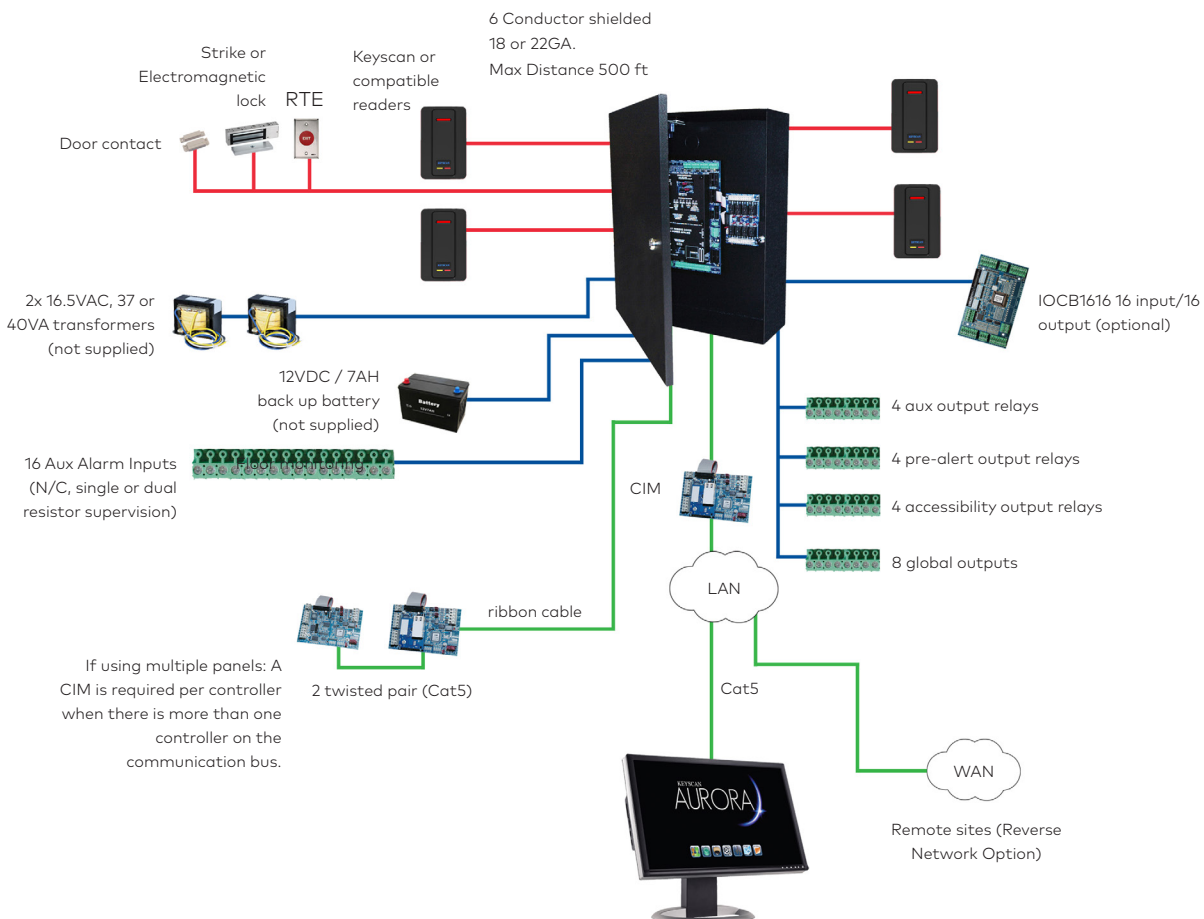

# Keyscan Access Control Unit Features

| Access Control Unit                          | CA150                       | CA250               | CA4500              | CA8500              | EC1500                   | EC2500                    |
|--|-----------------------------|---------------------|---------------------|---------------------|--------------------------|---------------------------|
| Doors/Elevator Floors Supported              | 1 door                      | 2 doors             | 4 doors             | 8 doors             | 1 cab<br>(up to 40 flrs) | 2 cabs<br>(up to 16 flrs) |
| Reader Ports                                 | 2 (in/out)                  | 2                   | 4                   | 8                   | 1                        | 2                         |
| Multi ACU Compatibility                      | Yes (Ethernet)              | Yes                 | Yes                 | Yes                 | Yes                      | Yes                       |
| System Status LEDs                           | Yes                         | Yes                 | Yes                 | Yes                 | Yes                      | Yes                       |
| Dual Processors                              | Yes                         | Yes                 | Yes                 | Yes                 | Yes                      | Yes                       |
| Flash Memory                                 | Yes                         | Yes                 | Yes                 | Yes                 | Yes                      | Yes                       |
| Power Fail Output                            | NA                          | Yes                 | Yes                 | Yes                 | Yes                      | Yes                       |
| Floor Monitor Inputs (supervised)            | NA                          | NA                  | NA                  | NA                  | Yes                      | Yes                       |
| <b>Inputs</b>                                |                             |                     |                     |                     |                          |                           |
| Request to Exit (RTE) Inputs (supervised)    | 1                           | 2                   | 4                   | 8                   | NA                       | NA                        |
| Door Contact Inputs                          | 1                           | 2                   | 4                   | 8                   | NA                       | NA                        |
| Auxiliary Inputs (supervised)                | 2                           | 8                   | 16                  | 16                  | NA                       | NA                        |
| I/O Input Expansion (with IOCB1616)          | NA                          | NA                  | 64                  | 64                  | NA                       | NA                        |
| <b>Outputs</b>                               |                             |                     |                     |                     |                          |                           |
| Auxiliary Output Relays                      | 1                           | 2                   | 4                   | 8                   | NA                       | NA                        |
| Expansion Auxiliary Output Relays            | NA                          | NA                  | 8                   | 8                   | NA                       | NA                        |
| I/O Outputs (with IOCB1616)                  | NA                          | NA                  | 64                  | 64                  | NA                       | NA                        |
| Door Output Relays                           | 1                           | 2                   | 4                   | 8                   | NA                       | NA                        |
| <b>Capacity</b>                              |                             |                     |                     |                     |                          |                           |
| No. of Credential-holders                    | 45,000<br>(90,000*)         | 45,000<br>(90,000*) | 45,000<br>(90,000*) | 45,000<br>(90,000*) | 45,000<br>(90,000*)      | 45,000<br>(90,000*)       |
| Transaction Buffer                           | 6000                        | 6000                | 6000                | 6000                | 6000                     | 6000                      |
| Schedules                                    | 512                         | 512                 | 512                 | 512                 | 512                      | 512                       |
| Groups                                       | 511                         | 511                 | 511                 | 511                 | 511                      | 511                       |
| Holiday Dates                                | 64                          | 64                  | 64                  | 64                  | 64                       | 64                        |
| <b>Connectivity</b>                          |                             |                     |                     |                     |                          |                           |
| Ethernet Ready                               | Equipped                    | Optional            | Optional            | Optional            | Optional                 | Optional                  |
| PoE - Power over Ethernet*<br>(IEEE 802.3af) | Equipped                    | NA                  | NA                  | NA                  | NA                       | NA                        |
| Global Integration ((CIM Required)           | Network/Server<br>Dependent | Capable             | Capable             | Capable             | Capable                  | Capable                   |
| CMAC Reverse IP                              | Equipped                    | Optional            | Optional            | Optional            | Optional                 | Optional                  |
| Serial Communication                         | Yes                         | Yes                 | Yes                 | Yes                 | Yes                      | Yes                       |

© dormakaba Canada, (2018). Information on this sheet is intended for general use only. \*Special hardware order. \*POE under license with Chrimar Systems Inc., US Patents 8,155,012 - 8,942,107 - 9,049,019. dormakaba Canada reserves the right to alter designs and specifications without notice or obligation. Printed in Canada.

dormakaba Canada Inc.  
901 Burns St., E.,  
Whitby, Ontario  
Canada L1N 0E6

1 888 539 7226

www.dormakaba.us

KKT2011 2018-05