



**SILENT
KNIGHT**

by Honeywell

IntelliKnight® Model EVS-50W

Intelligent 50 Watt Amplifier

The EVS-50W is an intelligent 50 watt amplifier for use with the 5820XL-EVS. The EVS-50W is used to amplify the audio message for distribution throughout the facility. Since it is designed as a self-contained distributed amplifier it can be conveniently located near the area of protection to reduce wiring demands.

For more information about the EVS-50W, or to locate your nearest source, please call 800-328-0103.

Description

Each EVS-50W is capable of producing 50-watts of audio power. Up to four EVS-50W's can be used on the voice evacuation system.

The EVS-50W has its own power supply with battery backup and four speaker circuits which can be expanded to eight speaker circuits with the optional EVS-CE4. The EVS-50W is fully supervised by the main panel for trouble conditions.

Features

- SBUS addressable, up to four EVS-50Ws per system.
- Each EVS-50W is supervised and has four onboard audio circuits expandable to eight with the EVS-CE4 for a system.
- EVS-50W uses an easy to install wire harness to connect the EVS-CE4 audio circuit expander.
- The EVS-50W has it's own power supply and backup battery.
- Selectable for 25 volt or 70.7 volt operation.
- Six-wire connection to EVS system: Two-wires for the voice bus and four-wires for the SBUS connections.
- UL 864 and UL 2572.

Listings

- UL 864 and UL 2572

Meets the requirements for NFPA 72 Local Protective Signaling Systems & Emergency Communication Systems.

Other Listings:
CSFM (pending)

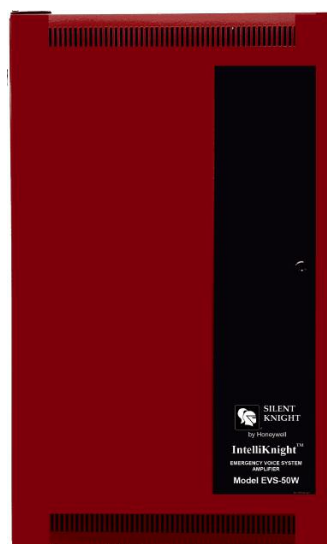

Model EVS-50W

Installation

The EVS-50W can be surface or flush mounted.

Compatibility

The EVS-50W is compatible with the following panel:

- 5820XL-EVS Voice Integration Panel with Fire Alarm Control

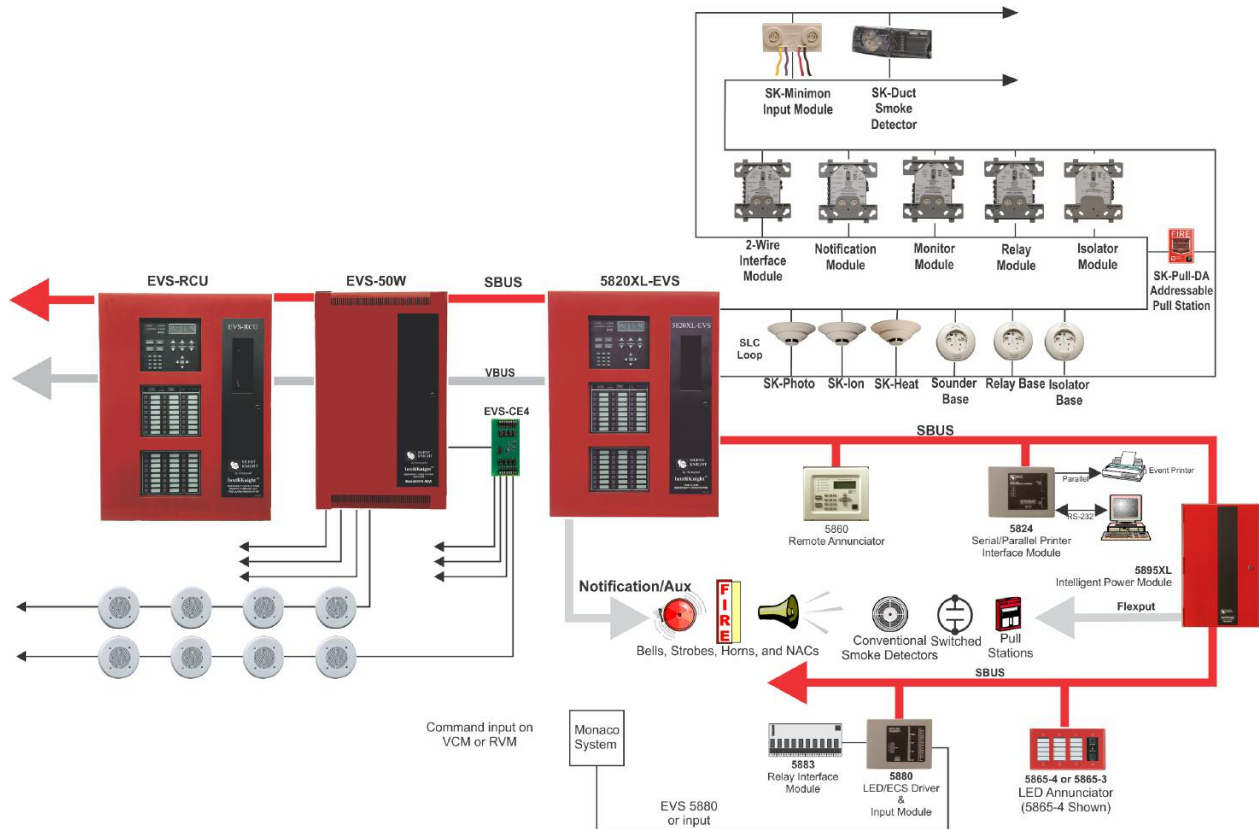

Specifications

Physical

Flush Mount Dimensions:
14.5"W x 24.75"H x 3.4"D
(36.8 W x 62.9 H x 8.7 D cm)

Overall Dimensions:
16"W x 26.25"H x 4.1"D
(40.6 W x 66.7 H x 10.5 D cm)

Color: Red

Environmental

Operating Temperature: 32°F – 120°F (0°C – 49°C)

Humidity: 10% – 93% non-condensing

Electrical

Primary AC: 120 VAC @ 60 Hz

Standby Current:

85 mA @ 25 Vrms; 100 mA @ 70.7Vrms

Alarm Current:

525 mA @ 25 Vrms; 580 mA @ 70.7 Vrms

Total Power: 50W @ 25 Vrms or 70.7 Vrms

- Circuit 1-4: Rated at 50 W each
- EVS-CE4 Circuits 5-8: Rated at 50 W each

Main ECS Panel SBUS Standby & Alarm: 10 mA

Battery Charging Capacity: 7 – 35 AH

Battery Size: 18 AH max allowed in cabinet. Use RBB accessory cabinet for larger batteries up to 35 AH per system.

Voice Integration Wiring:

- Six conductor
- Two voice bus
- Four SBUS

Ordering Information

EVS-50W Intelligent 50 Watt Amplifier

Accessories

EVS-CE4 Adds four additional audio circuits to the EVS-50W.

RBB Remote Battery Box Accessory Cabinet. Use for backup batteries up to 35 AH.

AB55 Remote Battery Box Accessory Cabinet Use for back batteries up to 55AH and too large to fit into EVS-50W Cabinet.



This document is not intended to be used for installation purposes. We try to keep our product information up-to-date and accurate. We cannot cover all specific applications or anticipate all requirements. All specifications are subject to change without notice. For more information, contact Silent Knight 12 Clintonville Road, Northford, CT 06472 Phone: (203) 484-7161, Fax: (203) 484-7118. For Technical Support, Please call 800-446-6444. www.silentknight.com.

Made in America

PN 350605 Rev B
© 2013 Honeywell International Inc.