



**SILENT
KNIGHT**

by Honeywell

IntelliKnight® Model 5820XL-EVS Addressable Fire Alarm Control Panel with Emergency Voice System

**The IntelliKnight System is the easy way
to make the most of fire alarm technology.**

IntelliKnight 5820XL-EVS offers an Emergency Voice System integrated with the fire alarm functions of the control panel. The 5820XL-EVS offers built-in digital communication, distributed intelligent power, a modular design and an expanded, easy to use interface. Powerful features such as drift compensation and maintenance alert are delivered in this powerful FACP from Silent Knight.

For more information about the 5820XL-EVS system, or to locate your nearest source, please call 800-328-0103.

Description

5820XL-EVS is an intelligent addressable fire alarm control panel combined with an Emergency Voice System (EVS). When the EVS features are enabled, they are integrated with the fire alarm and voice evacuation functions of the control panel. The 5820XL-EVS panel and accessories provide features to meet the requirements for Mass Notification Systems as described in UL 2572.

The basic 5820XL-EVS system can be expanded by adding modules such as 5860 remote annunciator, 5815XL signalling line circuit expander, 5824 serial/parallel printer interface module (for printing system reports), and 5895XL intelligent power module. 5820XL-EVS supports SD or SK devices.

Features

- Built in support for 99 SK detectors and 99 SK modules, expandable to 396 SK detectors and 396 SK modules using System Sensor protocol
- Built-in support for 127 SD devices, expandable to 508 SD devices using the SD protocol
- Support of up to four EVS-50W, EVS-100W or EVS-125W amplifiers for a maximum of 500 watts
- Each amplifier has four built-in speaker circuits expandable to eight
- 15 Recordable one minute messages that can be mapped to eight EVS buttons
- Can select EVS message as priority over fire
- Support of up to four EVS-RCU's. The EVS-RCU meets the requirements for a LOC
- Six Flexput™ I/O circuits
- Central station reporting by point or by zone
- Built-in synchronization for appliances from AMSECO®, Gentex®, Faraday, System Sensor, and Wheelock®
- Supports Class B (Style 4) and Class A (Style 6) configuration for SLC, SBUS, and Flexput circuits
- 13 pre-programmed output cadences (including ANSI-3.41) and 4 programmable outputs
- Built-in annunciator with 80-character LCD display
- RS-485 bus provides communication to system accessories
- UL listed for 520Hz signaling when used with EVS-100W and compatible speakers
- Programmable date setting for Daylight Saving Time



Model 5820XL-EVS

- Two built-in Form C programmable relays rated at 2.5 amps at 27.4 VDC
- 6 amp power supply and maximum charging capacity of 35 amp hours (An additional cabinet enclosure is required for batteries in excess of 18 amp hours)
- Improvements in SKSS software deliver five times faster uploads/downloads
- 16 built-in speaker group switches expandable to 32
- Built-in RS-232 and USB interface for programming via PC

Compatibility

The 5820XL-EVS is compatible with the following EVS components:

- EVS-50W - 50 watt amplifier
- EVS-125W - 125 watt amplifier
- EVS-100W - 50/100 Watt Amplifier
- EVS-100WBU - External Backup Amplifier
- EVS-RVM - Remote voice module
- EVS-SW24 - 24 switch expander
- EVS-VCM - Voice control module

P/N 351562 Rev E

© 2014 Honeywell International Inc.

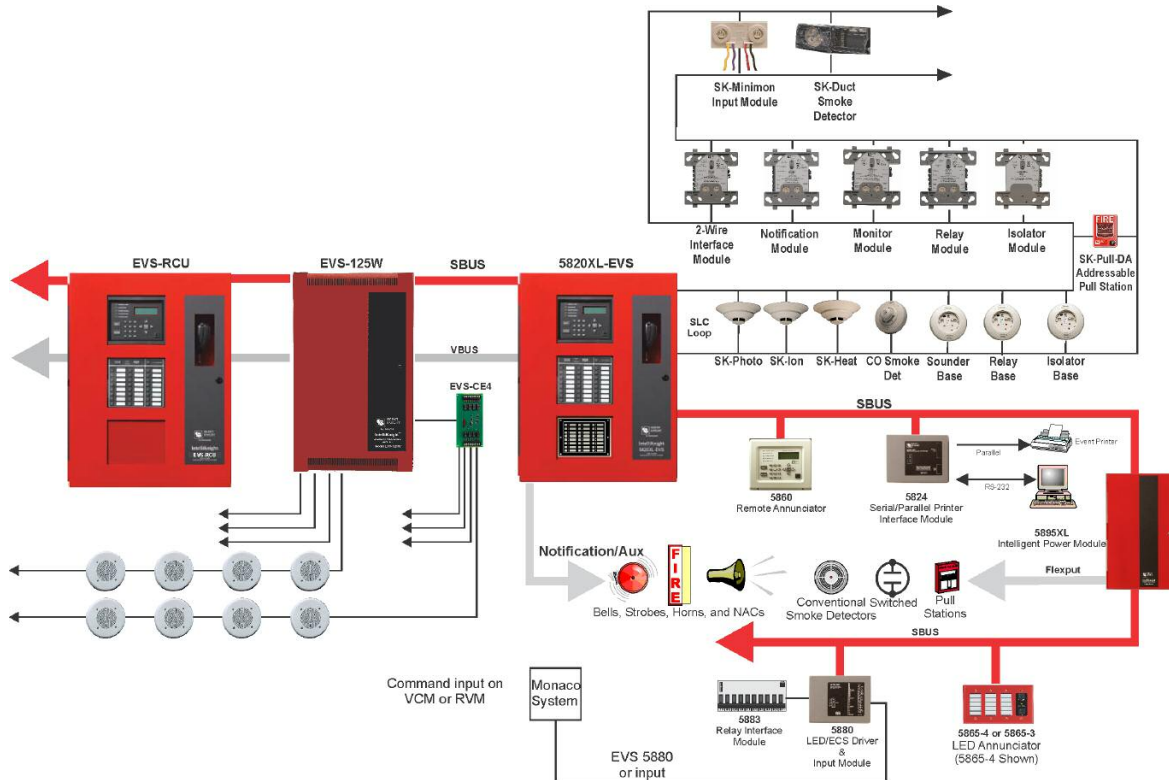

Physical

Flush Mount Dimensions:
 20.25"W x 26.75"H x 2.5"- 3"D
 (51.4 W x 68 H x 6.4-7.6 D cm)
 Overall Dimensions:
 20"W x 26.5"H x 4.6"D
 (50.75 W x 67.3 H x 11.8 D cm)
 Color: Red

Environmental

Operating Temperature: 32°F – 120°F (0°C – 49°C)
 Humidity: 10% – 93% non-condensing

Electrical

Primary AC: 120 VAC @ 60 Hz, 2.5A
 Total Accessory Load: 6A @ 27.4 VC power-limited
 Standby Current: 275 mA
 Alarm Current: 440 mA
 Battery Charging Capacity: 7 to 35 AH
 Battery Size: 18 AH max. allowed in control panel cabinet.
 Larger capacity batteries can be housed in RBB accessory cabinet
 Six Conductor Wiring: Two voice bus & four SBUS

Listings

NFPA 13, NFPA 15, NFPA16, NFPA 72: Central station; remote Signaling; Local Protective Signaling Systems; Auxiliary Protected Premises Unit; & Water Deluge releasing service. Suitable for automatic, manual, waterflow, sprinkler-supervisory (DACT non-coded) signaling services.
 - UL 864 and UL 2572

Meets the requirements for NFPA 72 Local Protective Signaling Systems & Emergency Communication Systems.
 Other Listings:
 CSFM; OSHPD (CA) OSP-0065-10

Compatible Devices

See the specification sheets listed below for a complete listing of the SD and SK devices.
 53624 SD Devices Data Sheet
 53623 SK Devices Data Sheet

Ordering Information

5820XL-EVS FACP with Emergency Voice System

EVS Accessories

- EVS-50W 50 Watt Amplifier
- EVS-125W 125 Watt Amplifier
- EVS-100W 50/100 Watt Amplifier
- EVS-100WBU External Backup Amplifier
- EVS-RVM Remote voice module
- EVS-CE4 4 Circuit Audio Expander
- EVS-SW24 24 Switch Expander
- EVS-VCM Voice Control Module
- VIP-TR Panel Trim Ring to flush mount
- SK-SCK Seismic Compliance Kit



This document is not intended to be used for installation purposes. We try to keep our product information up-to-date and accurate. We cannot cover all specific applications or anticipate all requirements. All specifications are subject to change without notice. For more information, contact Silent Knight 12 Clintonville Road, Northford, CT 06472 Phone: (203) 484-7161, Fax: (203) 484-7118. For Technical Support, Please call 800-446-6444. www.silentknight.com.

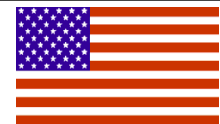

Assembled in America